



PROJECT TEASE

IT'S ALL ABOUT SEX.



H E L L O !

Morgan S. Varn

You can find me at:
www.morgansvarn.com

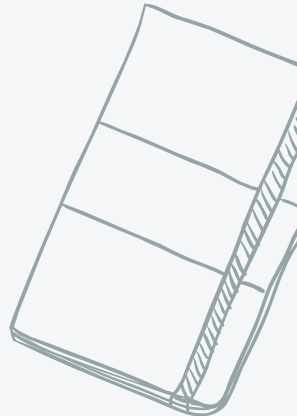



OBJECTIVES

1. Discuss current sexual health issues in women with disabilities
2. Meet Project TEASE
3. Introduce new resources for family, friends, and health professionals of women with disabilities

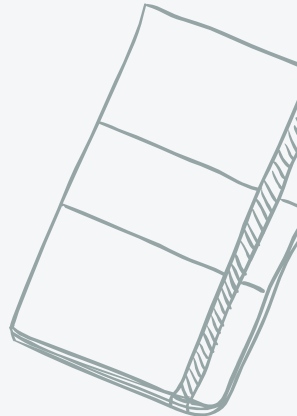



1.

IS THERE A NEED?

Current issues in SRH for women with disabilities



27 MILLION

women with disabilities in the US

That's more than the total
population of

GA, NC, & SC COMBINED

DISABILITY IN SC

1 IN 6
WOMEN

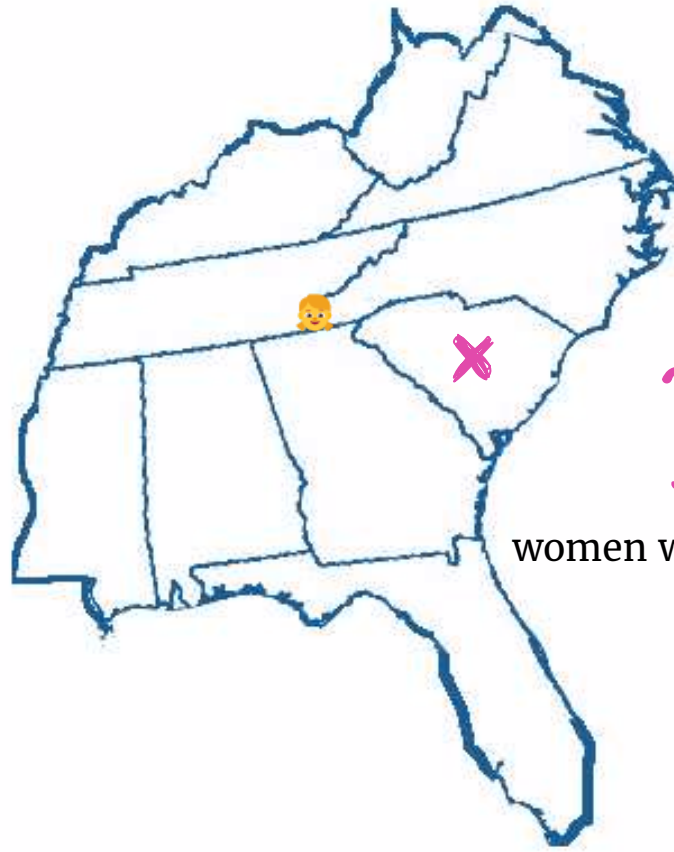





363,600

women with disabilities in SC

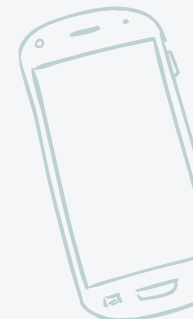

DISABILITY & SEXUALITY

- 
- 
- 
- 
- 
- 
- ✘Lack of appropriately tailored sex ed for girls and women with disabilities
 - ✘Current legislation does not require medically accurate info in SC sex ed curriculum
 - ✘Few, if any, social activities pertaining to sexuality and disability



DISABILITY & SEXUALITY

- ✗ Physical and economic barriers to sexual and reproductive healthcare (SRH)
- ✗ Current sex ed curriculum uses a predominately heteronormative, orgasmocentric view of sexuality
- ✗ Few, if any, opportunities to work with policy makers to address issues specific to their own sexual health



2.

PROJECT TEASE

A simple idea with potential for big impact



PROJECT SET-UP

It all started with an acronym.

T(RANSSPARENT) E(VOLVED) A(UTHENTIC) S(ELF) E(XPRESSIVE)

It's all about sex.

T
R
A
N
S
P
A
R
E
N
T

E
V
O
L
V
E
D

A
U
T
H
E
N
T
I
C

S
E
L
F-

E
X
P
R
E
S
S
I
V
E



A website designed to empower and enable women with disabilities to create a transparent, evolved, authentic, self-expressive sexual identity.

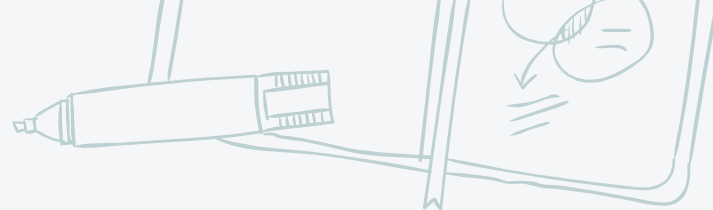

GOALS

Educate

Create a platform that can be used from home, in private by WWD, their families, aides, or physicians.

Advocate

Create opportunities to work with policy makers, researchers, and local education boards to reorganize the bounds of independent living by using their own unique voices.

Collaborate

Connect WWD to organizations on the local, state, and federal level. Create a forum in which ideas about their sexuality can be discussed, discretely or publicly. Give them an opportunity to educate the public about D & S.

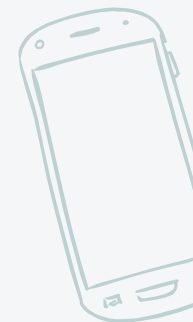

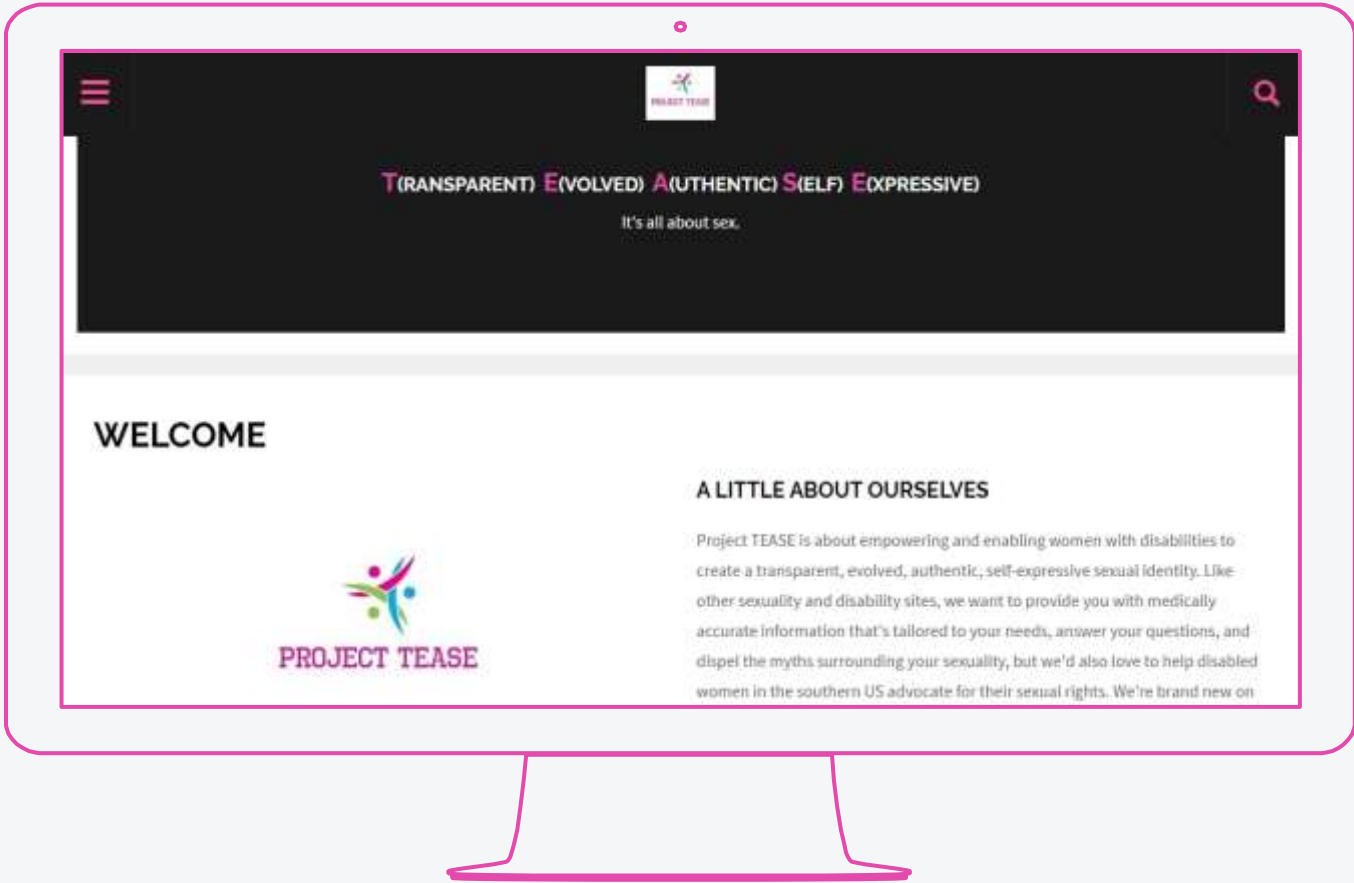

HOME PAGE



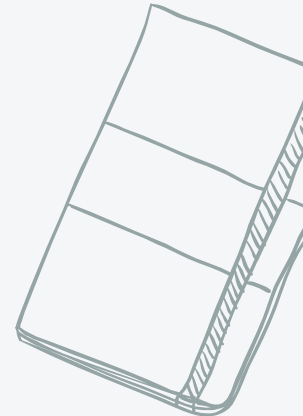
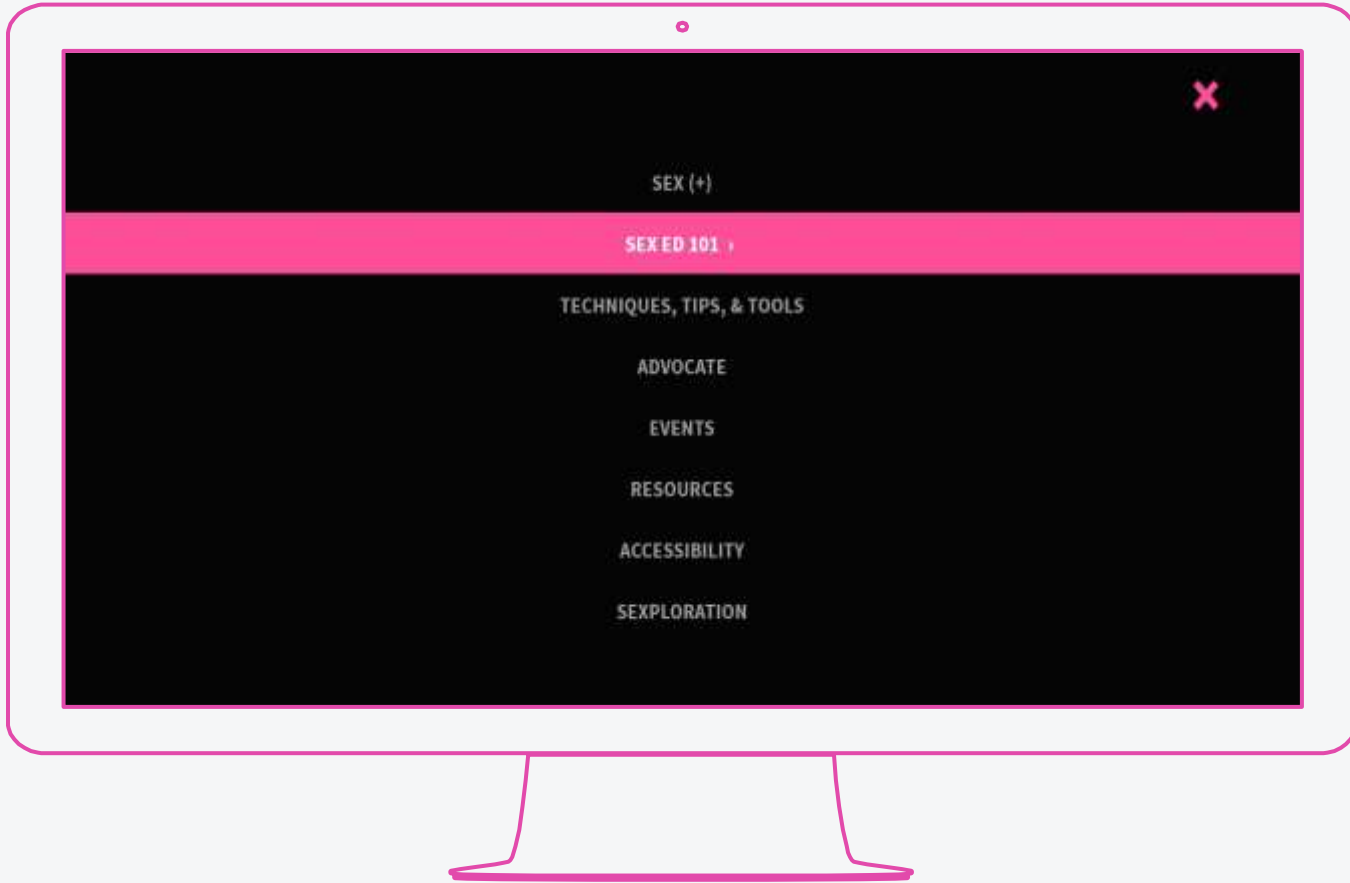

MENU



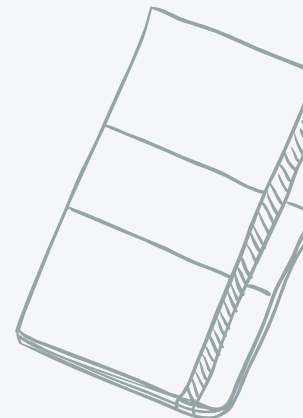
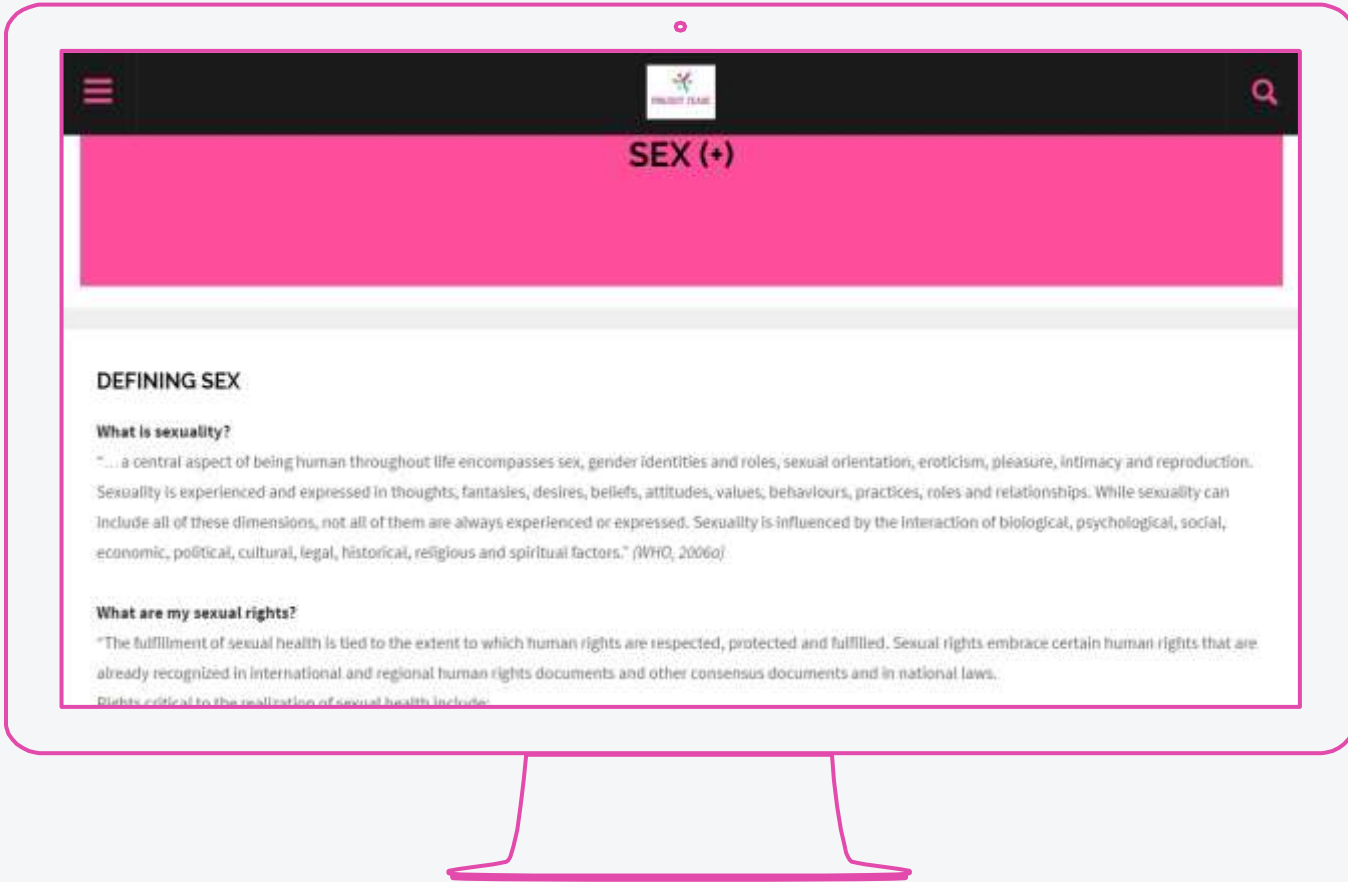

SEX (+)





Sexuality is the free expression of one's authentic self, in all of our lovely dimensions. We believe in transparency and honesty with ourselves and with whom we choose to share our sexuality.



We respect the rights of others to freely express themselves and require as much from those who we love, like, or enjoy.



We are sexual beings because we are human, not in spite of our humanity. We have the right to be educated about our bodies, our emotions, and our potential for love.



-Project TEASE.



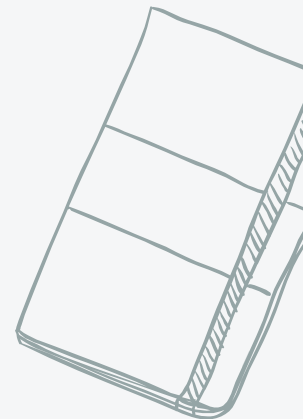
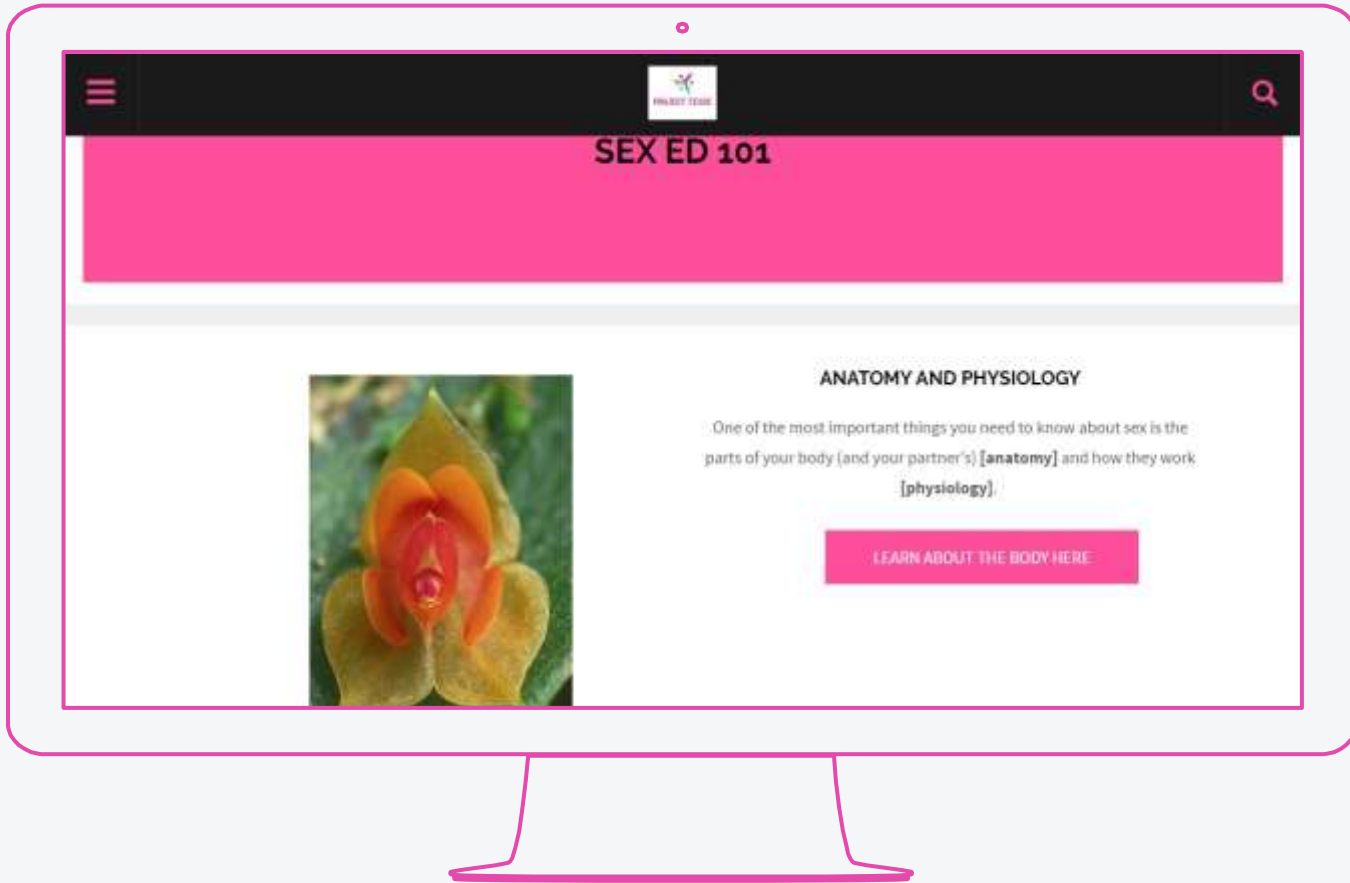

SEX ED 101









SPECIFICATIONS



Anatomy & Physiology

Highly detailed descriptions of female and male sex organs, as well as basic physiology of sexuality. These topics will be broadened for those with spinal cord injuries and other disabilities that include differences in tactile or neural processing.











SPECIFICATIONS

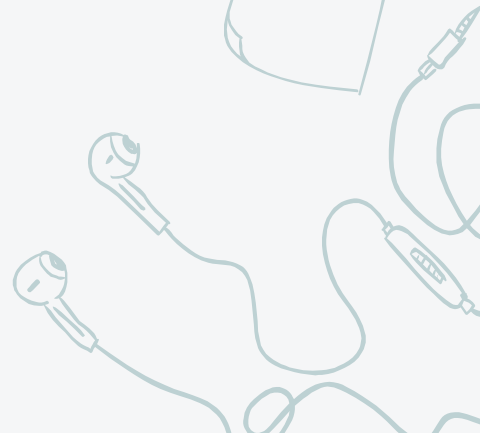

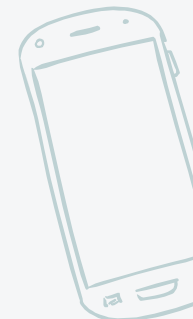
Personal Hygiene

A “how-to” guide to the vagina and penis. Basic information on cleanliness, symptoms and signs of general vaginal infections, and information about lubrications.











SPECIFICATIONS

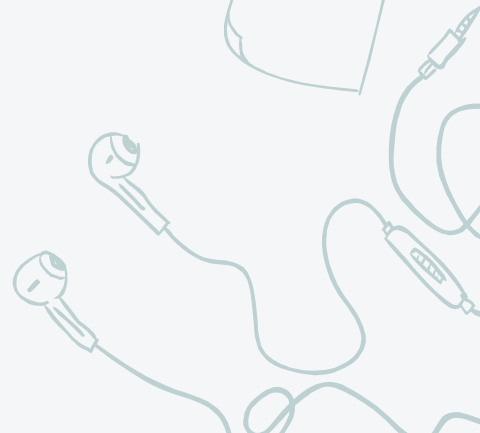

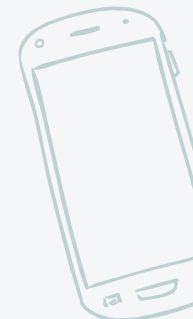
Dating & Relationships

Discussions about safety and trust, and building relationships with others, both disabled and non-disabled. Project TEASE would love to find a blogger for this page.











SPECIFICATIONS



Losing Your Virginity

Videos, descriptions, and models discussing both the choice to remain abstinent and to have sex. Information on the “first time” and what to expect. A brief overview of contraception methods and links to sites that provide condoms and more detailed information about protection. This may be very detailed for potential blind and loss of sight visitors.





SPECIFICATIONS

STI & STD

Pictures, descriptions, and information about signs and symptoms of STIs and methods of protection against them. Further links to sites that provide condoms and more detailed information about protection. A section including information about Hepatitis B, as the rate for this disease is high in women with disabilities.









SPECIFICATIONS

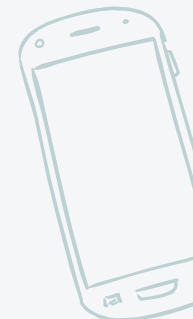

Restrictive Sex (Including Tips, Tricks, and Tools)

Discussions about positions for those who need assistance, and ways to lessen discomfort for those with chronic pain. Various tips from many different sites, as well as links to sites with toys that can be adjusted for different body types. Links and information about assistive devices. A broad discussion about alternative orgasm and non-orgasmic pleasure.











SPECIFICATIONS

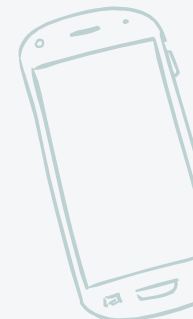

Vanilla & Kink

Topics including paraphilias and alternative sex, with heavy emphasis on RACK (Risk-Aware Consensual Kink) practice. Differential considerations for those with neural disorders. Those with chronic pain issues find that they can control the pain using this technique. Links to sites made by disabled women for those interested in kink and alternative sex.









SPECIFICATIONS



Abuse & Neglect

Criteria for healthy, happy relationships. A discussion concerning the “novelty factor” (this is a term loosely used to describe sex by a non-disabled person with a disabled person purely for the vicissitude of the act). Links for assistance in cases concerning neglect or abuse.

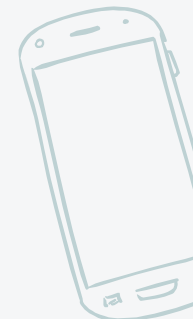







SPECIFICATIONS

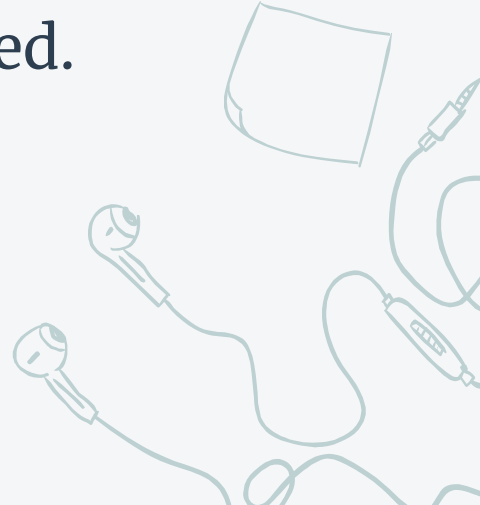

Gradient of Sexualities

Due to current time constraints, Project TEASE is not all inclusive of the LGBTQIAMSM population, but basic definitions and descriptions of the “gradient of sexualities” will be discussed. Links for women with disabilities who fall into these categories will be added.

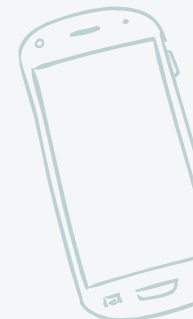

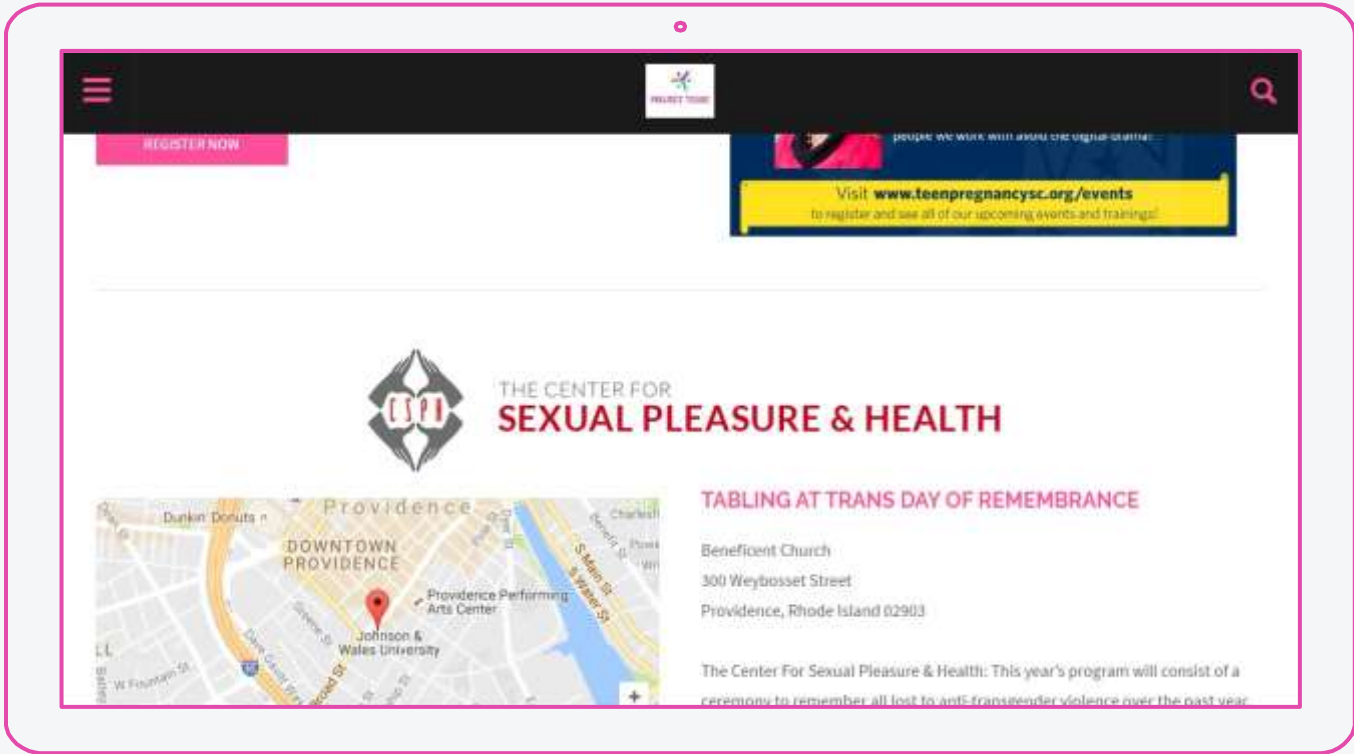

EVEN TS

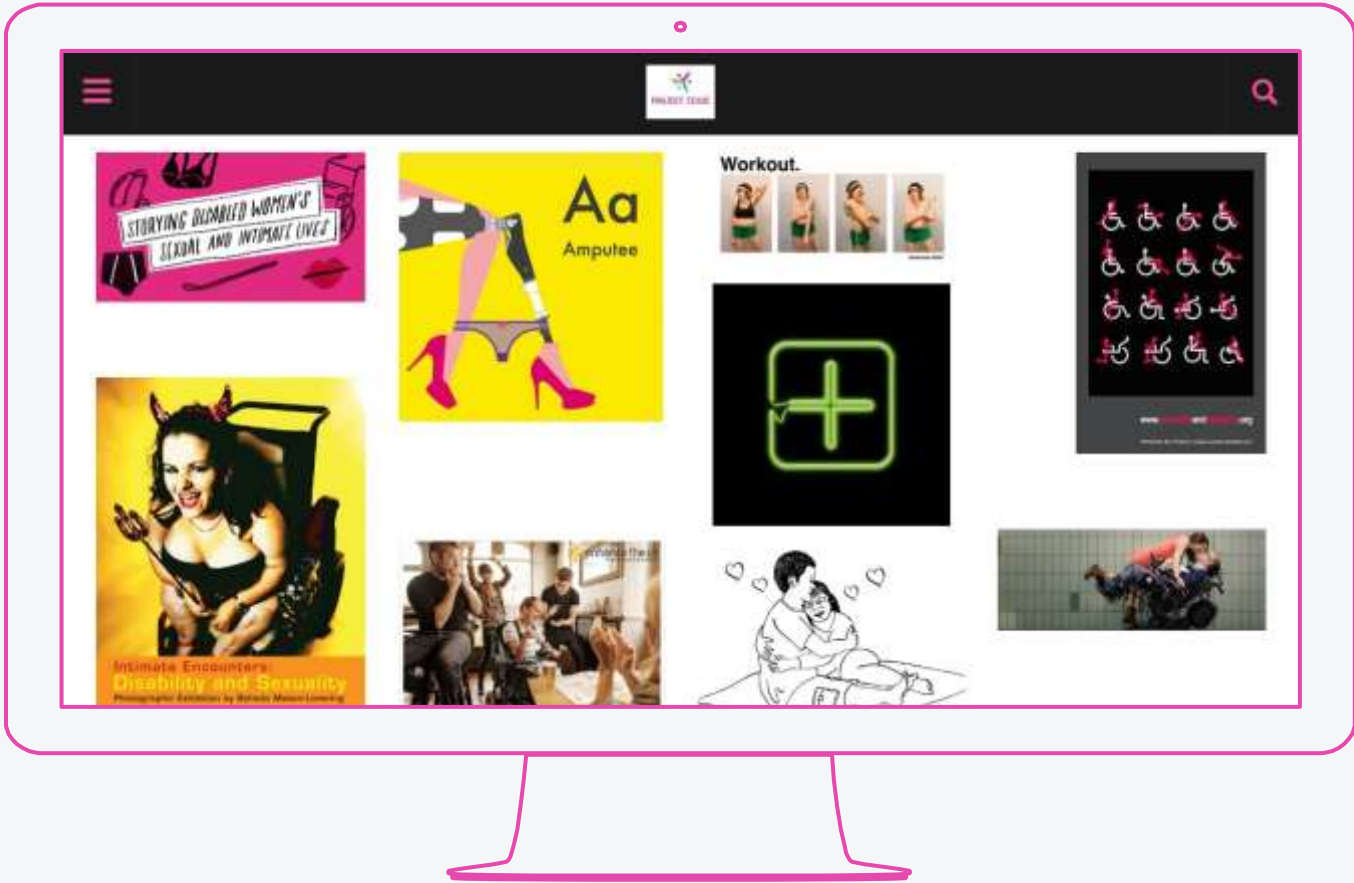

RESOURCES - LINKS TO OTHER D & S SITES

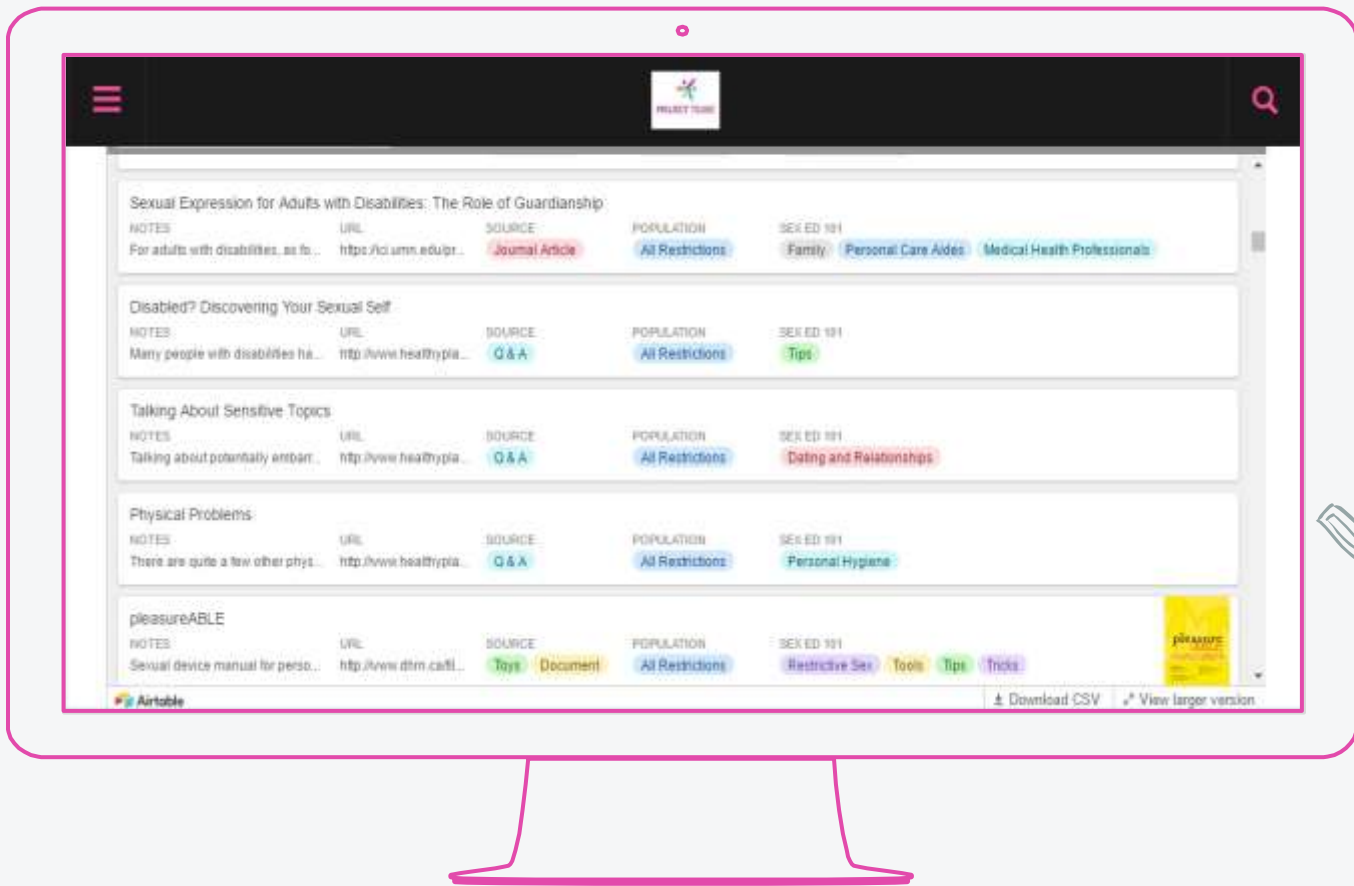

RESOURCES PAGE - 240 REFERENCES, LINKS, AND PDF





TECHNOLOGY & DISABILITY

- ✗ Phone application allows for voice control
- ✗ Improves communication skills for people with autism
- ✗ Assistive touch technology for people with motor control issues
- ✗ Allows for reading and writing of documents
- ✗ Facilitates communication with others
- ✗ Provides information



ACCESSIBILITY



✕The page is being tested in a number of ways, including NVDA, WAVE (Web Accessibility Evaluation Tool), iPad technology, and ChromeVox.

✕Text is simple with contrasting color, images are labeled, and the number of links per page are limited and include simple titles.



✕The website platform used is Weebly, primarily because html/css code is relatively easy to adjust by the builder.



✕Youtube videos are reviewed for closed captioning and auto captioning accuracy.



← → ↻ wave.webaim.org/report#/http://www.schiv-stdconference.org/

The following apply to the entire page:

h1

WAVE
web accessibility evaluation tool

http://www.schiv-stdconference.org/

Styles No Styles Contrast

Summary

WAVE has detected the following:

- 6 Errors
- 9 Alerts
- 0 Features
- 10 Structural Elements
- 3 HTML5 and ARIA
- 14 Contrast Errors

Panel Options

- DETAILS: A listing of all the WAVE icons in your page.
- DOCUMENTATION: Explanation of the WAVE icons and how you can make your page more accessible.
- OUTLINE: The heading structure of the web page.

HOME CONFERENCE INFO PLANNING COMMITTEE CALL FOR PRESENTATIONS SPONSORS/EXHIBITORS REGISTRATION PLWHA SCHOLARSHIPS STUDENTS ONLY

SPECIAL EVENT AWARDS

THE 2016 SOUTH CAROLINA HIV, STD AND VIRAL HEPATITIS CONFERENCE

h2 **h3** "BRIDGING THE GAPS: NEW OPPORTUNITIES, NEW EXPECTATIONS"

h4 OCTOBER 19-20, 2016

h5 COLUMBIA METROPOLITAN CONVENTION CENTER

h2 BRIDGING THE GAPS: NEW OPPORTUNITIES, NEW EXPECTATIONS

Experience South Carolina's only comprehensive conference on HIV, STD and Viral Hepatitis! This

Feedback | Powered by WebAIM

USING WAVE





PROBLEMS WITH AUTOCAPTIONS





the minority and little bit with some blacks
really is against it

PROBLEMS WITH AUTOCAPTIONS





LIMITATIONS TO THE PROJECT

✗Project TEASE is not designed for young girls with intellectual disabilities (ID). A daughter site should be created with their specific needs in mind. (see Pioneer)

✗Although the site may be used either by women without disabilities or men, a brother site for men with disabilities should be created.



LIMITATIONS TO THE PROJECT

✘Some cultural and religious views were neglected in the creation of Project TEASE. Further research may assist in creating additional information on this site in a more culturally diverse manner.

✘There is a growing population of LGBTQIAMSM within the disabled community. This creates the opportunity for yet another site with information tailored to their needs.

3.

ON THE SHOULDERS OF GIANTS

Following other pioneers in D&S



STORYING DISABLED WOMEN'S SEXUAL AND INTIMATE LIVES

April 14th, 2014 by Kirsty Liddiard [0 Comments](#)

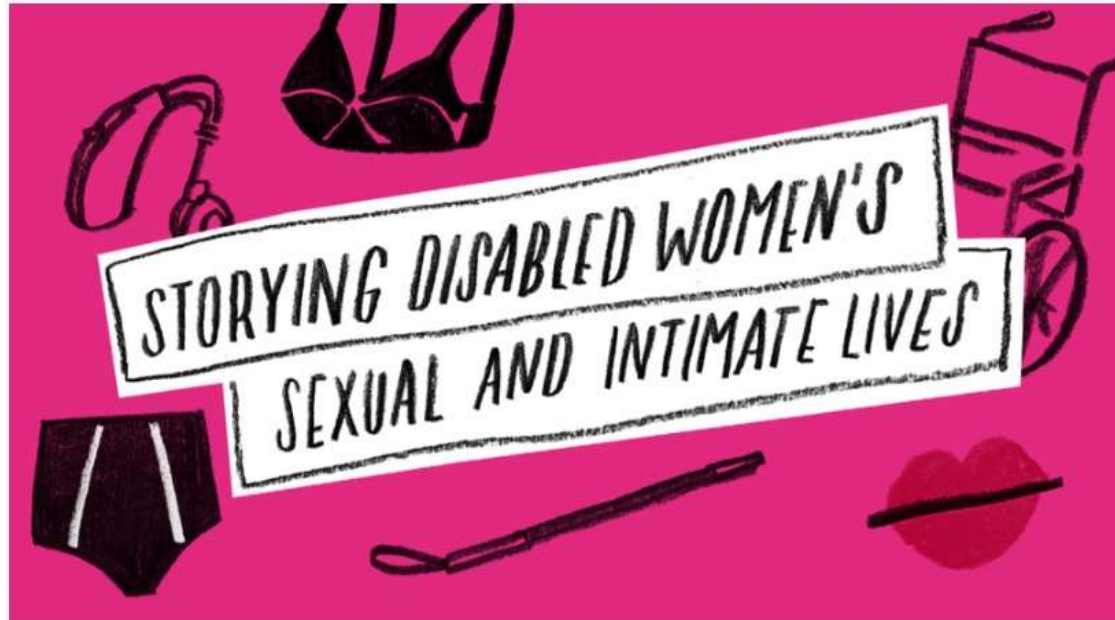

Illustration: Erin McPhee



MEET THE BLOGGERS
ANNOUNCEMENTS
BEHIND THE SCENES
BLOG SERIES
IN THE BLOG
SHAMELESS PODCASTS
WEB FEATURES
YOUTH VOICES
BLOG PITCHES

SHAMELESS-CANADA



End the Awkward

Two thirds of people feel awkward around disability. Don't hide from it.

End the Awkward: the basics

Five awkward things to avoid doing when you meet a disabled person

“You don't look disabled”

#EndTheAwkward

Not enough people know or interact with disabled people. Because of that they often don't know what to do. They panic, or worse, just avoid situations for fear of doing the wrong thing.

END THE AWKWARD -UK

AMERICAN ABLE: DISABILITY AND SEXUALITY

Feb 21, 2011

Tagged with: [advertisements](#) [American Able](#) [American Apparel](#) [disability](#) [model](#) [sexy](#)

Workout.



Advertisements by American Able parodying clothing retailer American Apparel have questioned whether or not disability can be sexy. In a sequence of photographs, a model with a disability, Jes Sachse, is shown posing in skimpy outfits. The twenty five year old model has Freeman-Sheldon Syndrome. This disability is characterized by a small mouth with taut, puckered lips that look the

ABOUT US

NCHPAD promotes increased participation in physical activity among people of all abilities. This blog, is a site where readers and contributors can share information and generate new ideas.



NATIONAL CENTER ON HEALTH, PHYSICAL ACTIVITY,
AND DISABILITY - ALABAMA



WHY AREN'T WE TALKING ABOUT DISABILITY AND SEX?



Like most young people here at Doctor Wellgood we spent a lot of time talking about sex. All sorts of sex in fact – the other sex, our sex, how much sex, good sex and bad sex. We're quite prepared to be upfront about the fact we think talking about sex (and thinking about it too) is totally normal and completely healthy.

Then something came along that made us realise that there was one aspect of sex we didn't ever talk about. That something was

**Doctor Wellgood
is absolutely FREE**

**but if you register
we'll make sure you're
the first with the news!**

DR. WELLGOOD-UK

sexuality and disability



BODY ▾

SEX ▾

RELATIONSHIPS ▾

PARENTING ▾

VIOLENCE ▾

WORKSHOPS ▾

BLOG ▾

ABOUT US ▾



SEXUALITY AND DISABILITY-MUMBAI



Sex and Disability

#UndressingDisability

UNDRESSING DISABILITY CAMPAIGN

THE LOVE LOUNGE

ENHANCE THE UK-UK

Story contents

The Short Story

The Full Story

1. Sexualities – then and now
2. Young people
3. Sexuality education
4. Sexual diversity in schools
5. Adult sexualities
6. Midlife and later life
7. People with disabilities
8. External links and sources



All images & media in this story



Send in your story



Print the Full Story



To comments

0 people have commented

Story: Sexualities

Part of page 7 – People with disabilities



Previous

Disability and sexuality

Next



TE ARA - NEW ZEALAND



Friendships and Relationships

32-page accessible booklet covering making friends, issues of trust, developing and ending a relationship, personal safety and making choices.



My Pregnancy, My Choice

2016 edition covering all aspects of ante-natal care from knowing you are pregnant to the first days with your baby.



Parenting Collection

Full collection of CHANGE Parenting Books. All images used in these books are available in our Media Gallery



Sexuality Collection

Contains all 5 accessible booklets about sex and relationships. All images in these booklets are available in our Media Gallery.



Lesbian, Gay, Bisexual and Trans

40-page accessible booklet covering sexuality, being lesbian, gay, bisexual and/or trans, talking about your sexuality, bullying and safe sex.

CHANGE-UK



JOIN ME!
Ask what you
can do.

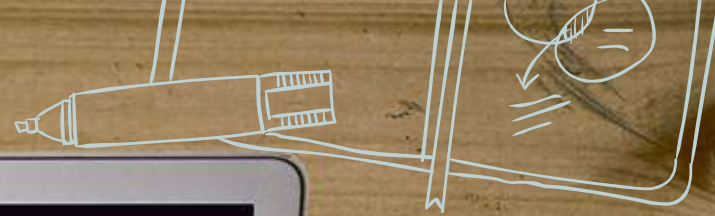
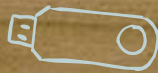
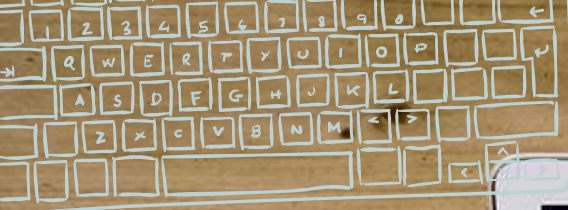



THANKS!

Any questions?

You can find me at:
www.morgansvarn.com
morgansvarn@gmail.com

